



TEKO Flex

DATASHEET | SPECIFICATIONS



CHARACTERISTIC

Modern LED public lighting fixture designed for installation on a pole or boom.

USE

- Pedestrian zones
- Outdoor areas
- Sidewalks
- Cycle paths
- Square

- LED
- DIMM AD
- DALI
- IP 66
- IK 09
- CB
- EMC
- Vibration

TECHNICAL SPECIFICATIONS

ELECTRICAL PARAMETERS

Light source	» LED
AC voltage	» AC 220–240 V / 50–60 Hz
Connection	» leading out cable » leading out cable with connector (G)
Driver	» electronic driver with surge protection L/N-Ground 10 kV
Surge protection	» additional surge protection 10 kV (S)
Fuse	» fuse 6,3 A (J)
Dimming	» non-dimmable (not labeled) » DALI (max. 3 core cable) » night dimming (A) » preparation for wireless communication » NEMA (N) » Zhaga (Z)
Constant lumen output	» CLO (C)

LIGHT PARAMETERS

Optical system	» roads (Mxx) » roads (Lxx) » directional (Pxx) » area (Uxx) » combined optics (Kxx) » BACK Light shades (BL1) » FRONT Light shades (FL1)
Light distribution	» direct
Color rendering index	» Ra > 70 » Ra > 80
Color temperature	» BLUE FREE (AMBER) » 2 200 K » 2 700 K » 3 000 K » 4 000 K » 5 000 K » 5 700 k » TW
Service life	» > 120 000 hrs. (L90)

CONSTRUCTION

Housing	» aluminum cast
Color	» RAL 7015/9006 » other RAL (on request)
Surface	» matte
Cover	» tempered glass

SAFETY

Protection class	» I » II
Ambient operating temperature	» -40 / +55 °C
Ingress protection	» IP 66
Impact protection	» IK 09
EMC	» YES
Vibration test	» YES
Static load test	» YES
Corrosion test – Salty spray	» YES (1 500 hours)
Lifetime test	» YES
Certification	» ENEC+ » ENEC » Zhaga-D4i » IDA Dark Sky Approved
CB mark	» YES
RoHS	» YES
REACH	» YES

MOUNTING

Method	» pole or boom (48–60 mm) » adjustable joint +/- 90°
Recommended height	» up to 12 m

This luminaire contains built-in LED lamps.

The lamps cannot be changed in the luminaire.

A++

A+

A

C

D

}

L

E

D

ELEKTRO-LUMEN | TEKO F 874/2012

LIGHT DISTRIBUTION CURVE

TEKO F U01 5k0 730 B124

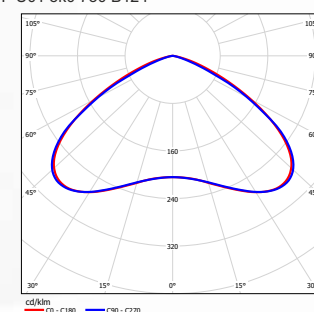

DIMENSIONS

TEKO F

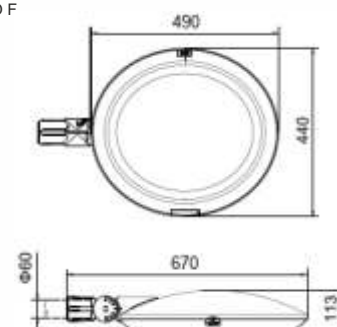

VARIANTS

DATASHEET TEKO F

VARIANTS (chip 3535)	POWER (W)				LUMINAIRE OUTPUT FLUX (lm)		LUMINAIRE EFFICIENCY (lm/W)	SERVICE LIFE (hrs.)	WEIGHT
	Color temperature (K)				min	max	Up to	L90B10	kg*
Catalog name	2200K (Ra 70)	2700K (Ra 70)	3000K (Ra 70)	4000K (Ra 70)					
TEKO F(lex) Mxx 2k0	14,5	12,8	12,3	11,7	1 673	1 926	164,6	> 100 000	9.2
TEKO F(lex) Mxx 3k0	22,6	19,5	18,3	17,5	2 510	2 890	165,1	> 100 000	9.2
TEKO F(lex) Mxx 4k0	30,6	27,1	25,1	23,9	3 346	3 853	161,2	> 100 000	9.2
TEKO F(lex) Mxx 5k0	39,6	34,3	32,1	30,6	4 183	4 816	157,4	> 100 000	9.2
TEKO F(lex) Mxx 6k0	42,7	42,6	39,5	37,4	5 020	5 779	154,5	> 100 000	9.2
TEKO F(lex) Mxx 7k0	50,9	44,2	41,6	39,2	5 856	6 742	172,0	> 100 000	9.2
TEKO F(lex) Mxx 8k0	59,5	51,4	48,2	45,4	6 693	7 706	169,7	> 100 000	9.2
TEKO F(lex) Mxx 9k0	68,2**	59	55,4	52,3	7 529	8 669	165,8	> 100 000	9.2
TEKO F(lex) Mxx 10k0	78**	66,6**	62,5**	58,9	8 366	9 632	163,5	> 100 000	9.2
TEKO F(lex) Mxx 12k0	-	83,9**	77,8**	72,9**	10 039	11 558	158,5	> 100 000	9.2

VARIANTS (chip 5050)	POWER (W)					LUMINAIRE OUTPUT FLUX (lm)		LUMINAIRE EFFICIENCY (lm/W)	SERVICE LIFE (hrs.)	WEIGHT
	BLUE FREE (AMBER)	2200K (Ra 70)	2700K (Ra 70)	3000K (Ra 70)	4000K (Ra 70)	min	max	Up to	L90B10	kg*
TEKO F(lex) Lxx 2k0	14,2	13,8	12,6	12	11,4	1 695	1 892	166,0	> 100 000	9.2
TEKO F(lex) Lxx 3k0	21,1	20,7	18,9	17,7	16,9	2 543	2 837	167,9	> 100 000	9.2
TEKO F(lex) Lxx 4k0	28,2	27,7	25,5	23,6	22,6	3 390	3 783	167,4	> 100 000	9.2
TEKO F(lex) Lxx 5k0	35,8	35,1	32,3	29,8	28,2	4 238	4 729	167,7	> 100 000	9.2
TEKO F(lex) Lxx 6k0	39,9	39,1	39,4	36,3	34,3	5 086	5 675	165,5	> 100 000	9.2
TEKO F(lex) Lxx 7k0	46,6	46,2	42,3	39	37,2	5 933	6 621	178,0	> 100 000	9.2
TEKO F(lex) Lxx 8k0	54,1	53,7	48,4	44,7	42,5	6 781	7 566	178,0	> 100 000	9.2
TEKO F(lex) Lxx 9k0	61,9**	60,6	55,4	51,2	48,3	7 628	8 512	176,2	> 100 000	9.2
TEKO F(lex) Lxx 10k0	69,9**	68,5**	62,3**	57,4	54,3	8 476	9 458	174,2	> 100 000	9.2
TEKO F(lex) Lxx 12k0	-	-	76,9**	70,8**	66,7**	10 171	11 350	170,2	> 100 000	9.2

* The weight may vary slightly depending on the luminaire variant.

** Can not be produced under ENEC licence.

Luminaire ambient temperature TQ 25 °C
Initial color consistency: ≤ 5 SDCM
IDA fixture seal of approval relates to ≤ 3 000 K
To meet IDA requirements, the luminaires must be installed horizontally with the road
Optical and electrical parameters tolerance ± 10 %

When using the CLO function, the initial power and luminous flux is 10 % lower than the value shown in the table. LDT curves with CLO function have the letter "C" at the end of their marking.

The term BLUE FREE (AMBER) in lighting technology refers to light with a minimum amount of the blue part of the light spectrum (< 2%).

CODE DESCRIPTION

TEKO F TW II M01BL1 8k0 730 B124 43CAZ SJG H3S ENEC

TEKO	F	TW	II	M01	BL1	8k0	730	B124	43CAZ	SJG	H3S	ENEC	
Name													
TW													Tunable White
Class													
Without marking													Class I
II													Class II
Optical system													
M01													Roads
L01													Roads
P01													Directional
U01													Area
K01													Combined optics
BL1													BACK Light shades
Luminous flux marking (source)													
Ra 70 / 3 000 K													
LED module marking													
B													LED module type
1													
2													
4													Mask type
Driver type													
43													DALI driver + 3 pole terminal block
4													DALI driver
1													on/off driver
D													D4i driver (for Zhaga connector)
C													Constant luminous flux (CLO)
A													AstroDim
Z													Zhaga connector, 4 pin (D4i driver)
N													NEMA connector, 7 pin (DALI driver)
S													Surge protection 10 kV
J													Fuse 6,3 A
G													Gesis connector
H													H05(07)RN-F cable (1 mm ²)
C													CYKY cable (1,5 mm ²)
2													2 core cable
3													3 core cable
S													Standard – 25 cm length of cable (led out of the luminaire)
1													1 meter (length in whole meters)
ENEC certification													